

..... 7

..... 12

..... 15

..... 20

..... 31

..... 39

| | |
|-------|-----|
| | 223 |
| | 226 |
| | 227 |
| | 231 |
| | 235 |
| | 236 |



[]

| | | |
|---|----|--|
|  | 危險 | 危險标识表示，如果忽视该警告，而进行了错误的操作，就可能造成重大的人身伤亡事故。 |
|  | 注意 | |







| | | | | | | | |
|----|---|---|---|---|---|---|----------|
| | | 表示可能会造成危险的事项 | | | | | |
| | | 表示必须提醒注意的事项 | | | | | |
| 旋轉 |  |  | 一般性注意 |  | 小心触电 |  | 小心物 落 |
| | | 表示严禁的事项 | | | | | |
| 閉閉 |  |  | 一般性禁止 事項 |  | 禁止拆卸 |  | 禁止使 火 |
| | | 表示必须强制执行的项目 | | | | | |
| |  | 一般性强制 项目 |  | 必须接地 |  | | |







1.



1-1







| 危 险! | |
|---|---|
|  ■小心触电 绝对禁止卸下盖板，否则会有触电造成人身伤亡的危险。 | |
| 等情况时，应立即切断电源，并和销售商取 干粉），切勿用水进行灭火。 |  ■小心火灾 从装置中发生异味、异常噪音、冒烟、火花 取得联系。 万一发生火灾，请使用电气火灾用灭火器（ |



1-2





| 注 意! | |
|--|--|
|  ■在启动装置之前，先确认负载的安全状况，然后再根据使用说明书进行运转操作， 否则会产生电气等事故的危險。 | |
|  ■在装置周围，切勿吸烟和使用烟火。 | |
|  ■设备上面切勿搁置存有水的容器，如花瓶等。 溢出来的水会渗入设备内部而导致火灾。 | |
|  □切勿坐在或站在设备的上面，也不要倚靠或当作踏板， 否则会导致跌倒而导致人身伤害。 | |
|  □切勿将棉棒、手指等插入风窗。 转动的风窗会使人受到伤害。 | |
|  □短转中，输入端子和输出端子之间切勿短路。 电流回流产生热量会导致人员灼伤和视觉损害。 | |
|  □绝对禁止在以下的场合使用。 a) 与人的生命直接相关的医疗设备。 b) 有可能导致人身伤害的设备。 c) 对业主、公共事业上一些重要网络系统的系统等。 d) 以这些为标准的设备。 否则可能对人身安全，公共机能的维持产生重大影响。 用于上述负载设备情况时，请务必与本公司咨询。 | |







| | |
|---|--|
| 注意!! | |
|  | <p>■绝对禁止在如下环境中使用或保管。 否则会因设备的故障、损坏及老化而导致发生火灾。</p> <p>◆存在潮湿、潮湿或水蒸气、油、灰尘、粉尘或腐蚀性气体的场所。</p> <p>◆存在腐蚀性气体、粉尘、可燃性气体及液体的场所。</p> <p>◆存在粉尘、腐蚀性气体、蒸汽、可燃性气体及液体的场所。</p> <p>◆超过海拔3000米的场所。</p> <p>◆其他类似于上述的场所。</p> <p>■请安装在金属等不会燃烧的物体上。</p> |
|  | <p>■请按照使用说明书，将设备安装在能够承受其重量的场所。 否则可能就会因设备跌落而造成人身伤害。</p> |
|  | <p>■进排气口切勿堵塞。</p> |
|  | <p>! 请勿放在可燃物附近。</p> |
|  | <p>■谨防杂物进入变频器内部或附着在冷却风扇上。 否则有引发火灾事故的危险。</p> |
|  | <p>■请勿将变频器安装在潮湿的场所。</p> |



| | |
|---|---|
| 注意! | |
|  | <p>■在搬运和移动过程中，请勿让设备倾斜。 否则由于设备的倒下会造成人身伤害。</p> |
|  | <p>! 在搬运和移动过程中，请勿让设备倾斜。 否则由于设备的倒下会造成人身伤害。</p> |

| 危 险! | |
|---|---|
|  | <ul style="list-style-type: none"> ■请委托专业人员进行布线施工。 布线施工不当可能造成触电和火灾。 |
|  | <ul style="list-style-type: none"> ■请勿将交流电源连接到输出端子 (U、V、W) 上。 |
|  | <ul style="list-style-type: none"> ■请勿在超过额定电压的情况下使用。 否则有引起人身伤害和火灾的危险。 |
| 接接在直流端子 (P、X) 上。 | <ul style="list-style-type: none"> ■请勿将电阻直 接连接到端子 上。 |
|  | <ul style="list-style-type: none"> ■端子台接线，请参考规定的接线图进行。 |
|  | <ul style="list-style-type: none"> ■请确认产品的额定电压和交流电源的电压是否一致。 否则会造成人身伤害和火灾的危险。 |
|  | <ul style="list-style-type: none"> ■所用电缆的种类和线径，请参考使用说明书指定的电缆。 |
|  | <ul style="list-style-type: none"> □布线，务必在设备固定以后进行。 否则有触电和火灾的危险。 |

| 注 意! | |
|--|--|
|  | <ul style="list-style-type: none"> ■变频器 电机及布线会发生干扰。请注意外围设备的误动作。 |
|  | <ul style="list-style-type: none"> ■输入输出端子必须，具有绝缘罩。否则有触电和火灾的危险。 |

| 危 险! | |
|---|---|
| ■ 务必在安装好前盖板后才可接通输入电源。另外，请勿在电源接通期间卸下盖板。 | |
|  | 否则有触电的危险。 |
|  | ■ 请勿用潮湿的手操作开关。 否则有触电的危险。 |
| 变频器的端子。 |  |
| | ■ 在变频器的电源接通期间，即使电机处在停止状态，也不要触摸变频器端子。 否则有触电的危险。 |
| 请勿靠近电机设备。 |  |
| | ■ 如果选择了再启动功能，设备在报警停止时就会突然重新启动，所以请务必注意。 （请将系统设计成即使再启动时也能确保人身安全）。 |





| 注意! | |
|---|-----------|
| ■ 如果在运行中解除报警，设备会突然重新启动。请务必先断开运行再解除报警。 | |
|  | 否则有触电的危险。 |
| ■ 如果在解除报警后，设备会突然重新启动。请务必先断开运行再解除报警。 | |
|  | 否则有触电的危险。 |
| ■ 在拆卸片、门或片状物的距离会变得很短，所以请勿触摸。否则有受伤的危险。 | |
|  | 否则有触电的危险。 |
| ■ 变频器可以很便捷地设定从低速到高速的运转，请在充分确认电机或机械设备的范围后，再运转。 | |
|  | 否则有触电的危险。 |
| ■ 请务必保持制动时，请另外设置制动器。否则，有引起人身伤害的危险。 | |
|  | 否则有触电的危险。 |
| ■ 请务必在断电状态下进行维护、检查和更换零部件等作业。 | |
|  | 否则有触电的危险。 |

| 注 意! | |
|---|---|
| ■ 除专业电气施工人员外，其他人员不可进行维护、检查和更换零部件等作业。 | |
|  | 否则有触电的危险。 |
| ■ 进行维护和检查时，请将输入电源断开（OFF），待 [CHARGE]（充电）指示灯熄灭后， |  |
| | ■ 进行维护和检查时，请将输入电源断开（OFF），待 [CHARGE]（充电）指示灯熄灭后，再进行维护、检查和更换零部件等作业。否则有触电和人身伤害的危险。 |

1-8

| | |
|---|-------------------------------|
| 注 意! | |
|  | ■ 废弃本产品时，请委托专门的工业废弃物处理机构进行处理。 |

1-9

| | |
|---|--|
| 危 险! | |
|  | ■ 严禁擅自对产品进行改造。 |
|  | ■ 本产品是为三相感应电机运转而设置的。所以不能用于单相电机或其它的用途，否则有引起火灾事故的危险。 |
|  | ■ 不能将本产品用于与生命维持装置等与人体危险有直接关系的场合。 否则有引起事故的危险。 |
| 可能引起重大事故、或引发重大损失时，对于这类设备请配置 |  ■ 由于本产品发生故障而安全装置。 否则有引起事故的危险。 |

2.

2-1

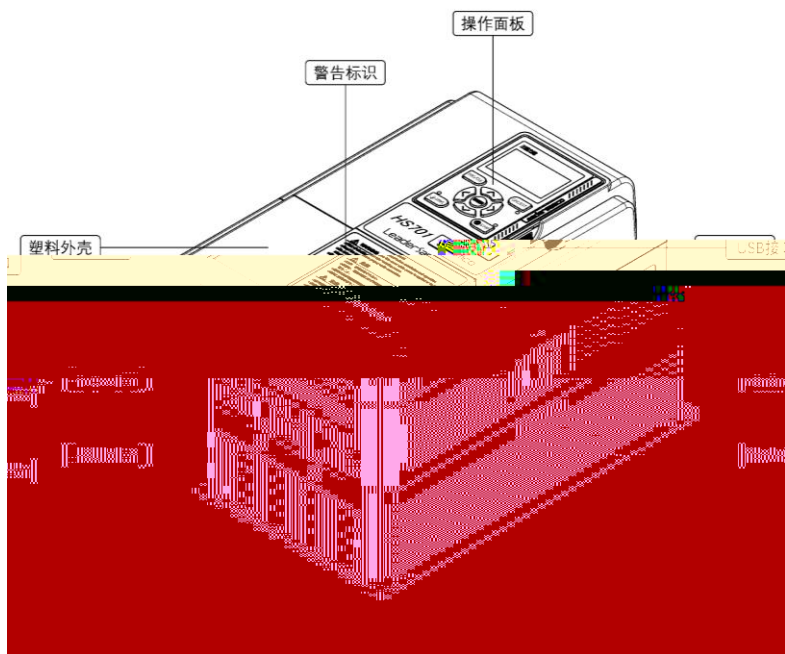

2-2

HS701 - 4 A013 D - N L

带LCD操作面板
无EMC滤波器
双规格模式
额定输出电流
三相400V
系列名

2-3

三墾力達®

| | |
|--|---|
| 变频器规格 | MODEL: HS701-4A013D-NL |
| 输入电源规格 | SOURCE: 3-Phase 400V 50/60Hz |
| 输出规格 | OUTPUT: 120A 37A |
| 标准适配电机 | MOTOR: 5.5kW/7.5kW |
| 过载率 | OVERLOAD: 150% 1 min / 120% 1 min |
| 产品序列号 | SERIAL No.: C123456789 |
| 产品重量 | MASS: 3.5kg |
| 条形码 |  |
| SANKEN L.D. ELECTRIC (JIANG-YIN) CO., LTD | |

2-4

3.

3-1

3-1

| | |
|--|--|
| | |
| | |
| | |
| | |
| | |
| | |
| | |
| | |

3-2

| | |
|--|--|
| | |
| | |
| | |

3-2

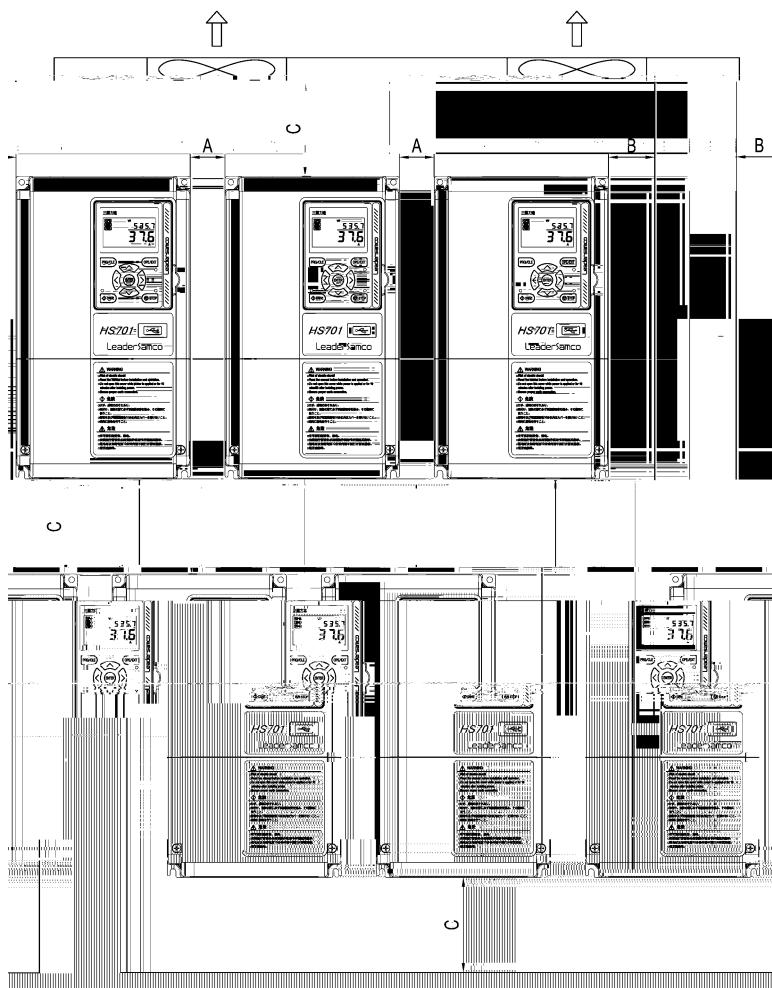

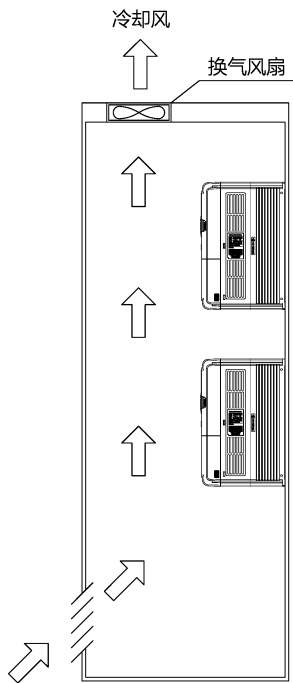
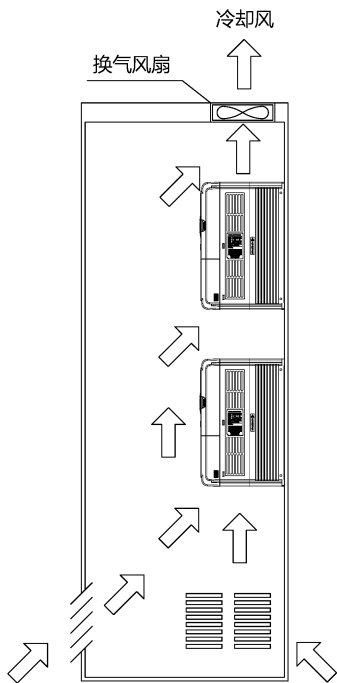

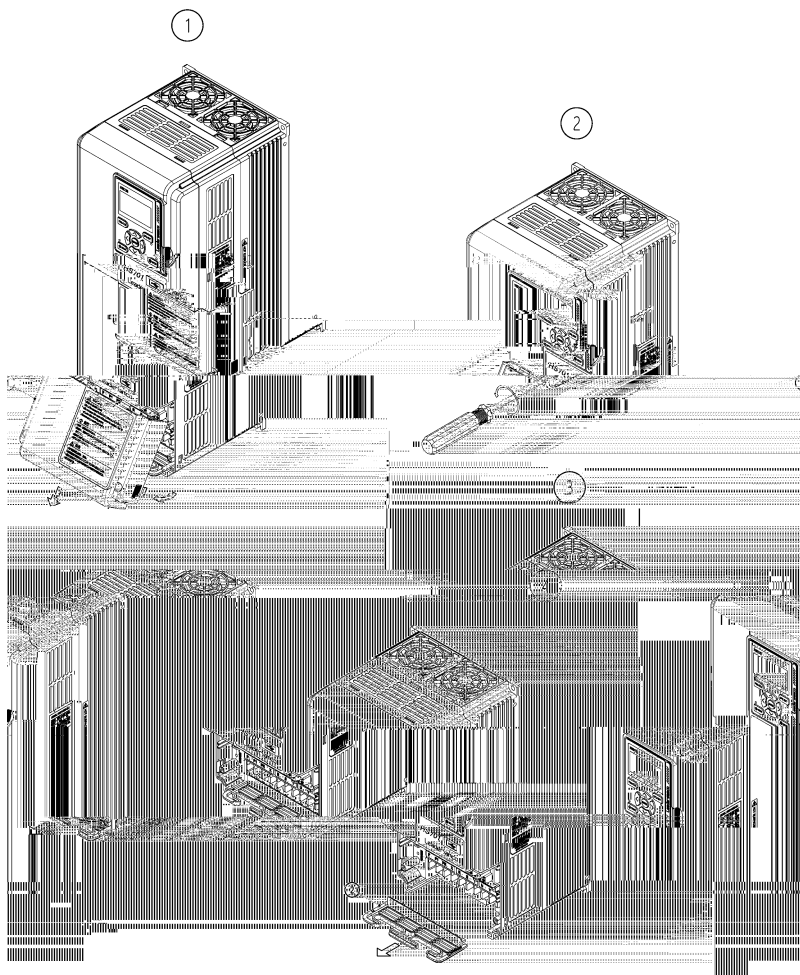

2

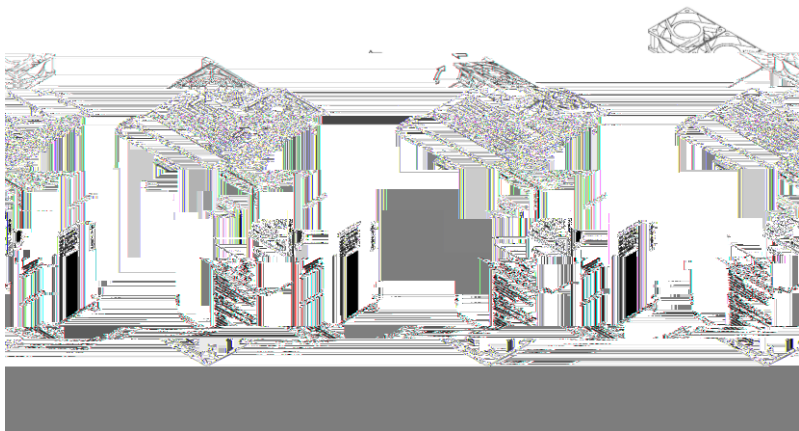

3

4.

4-1

4-2

4-2-1

| | | |
|---|--|--|
| | | |
| | | |
| | | |
| | | |
| | | |
| | | |
| | | |
| | | |
|  | | |

4-2-2

400V

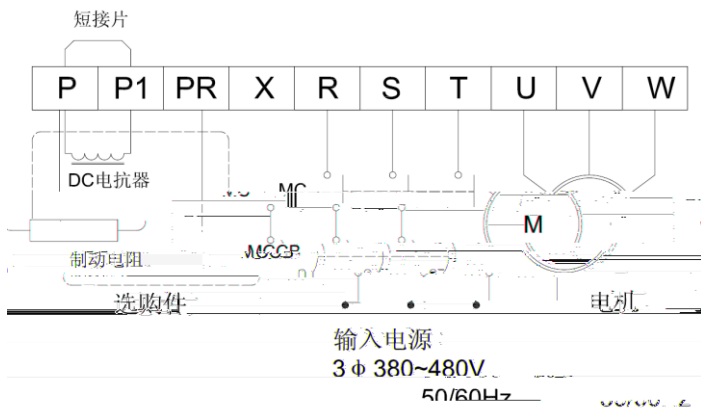

| | | | |
|--|--|--|--|
| | | | |
| | | | |
| | | | |
| | | | |
| | | | |
| | | | |
| | | | |
| | | | |
| | | | |
| | | | |

4-2-3

| | | | | | | | |
|--|--|--|--|--|--|--|--|
| | | | | | | | |
| | | | | | | | |
| | | | | | | | |
| | | | | | | | |
| | | | | | | | |
| | | | | | | | |
| | | | | | | | |
| | | | | | | | |
| | | | | | | | |
| | | | | | | | |
| | | | | | | | |
| | | | | | | | |

4-3-1

4-3-2

4-1



4-4

| | | | |
|--|--|--|--|
| | | | |
| | | | |
| | | | |

4-5

4-5-1

4-5-2

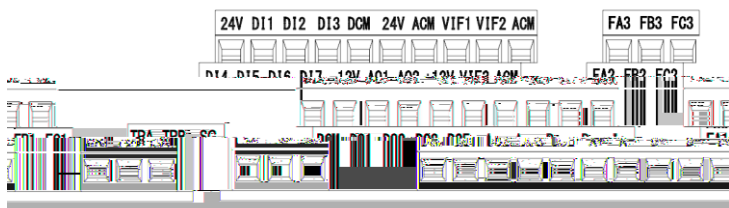

4-5-3

| | | | | |
|--|--|--|--|--|
| | | | | |
| | | | | |
| | | | | |
| | | | | |
| | | | | |
| | | | | |
| | | | | |
| | | | | |
| | | | | |
| | | | | |
| | | | | |
| | | | | |
| | | | | |
| | | | | |
| | | | | |
| | | | | |

| | | | | |
|--|--|--|--|--|
| | | | | |
| | | | | |
| | | | | |
| | | | | |
| | | | | |
| | | | | |
| | | | | |
| | | | | |
| | | | | |
| | | | | |
| | | | | |
| | | | | |
| | | | | |
| | | | | |
| | | | | |
| | | | | |
| | | | | |
| | | | | |
| | | | | |
| | | | | |
| | | | | |
| | | | | |
| | | | | |
| | | | | |
| | | | | |
| | | | | |
| | | | | |
| | | | | |
| | | | | |
| | | | | |
| | | | | |
| | | | | |
| | | | | |
| | | | | |
| | | | | |
| | | | | |
| | | | | |
| | | | | |
| | | | | |
| | | | | |
| | | | | |
| | | | | |
| | | | | |
| | | | | |
| | | | | |
| | | | | |

4-5-4

DC24V

DI

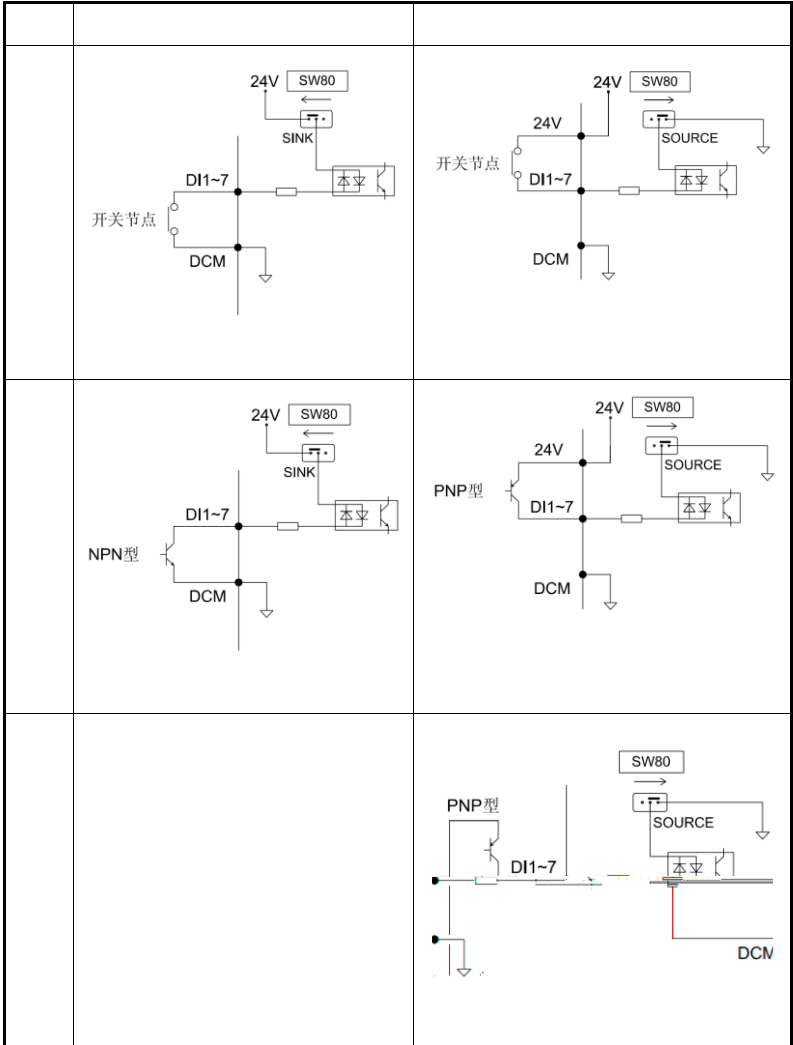

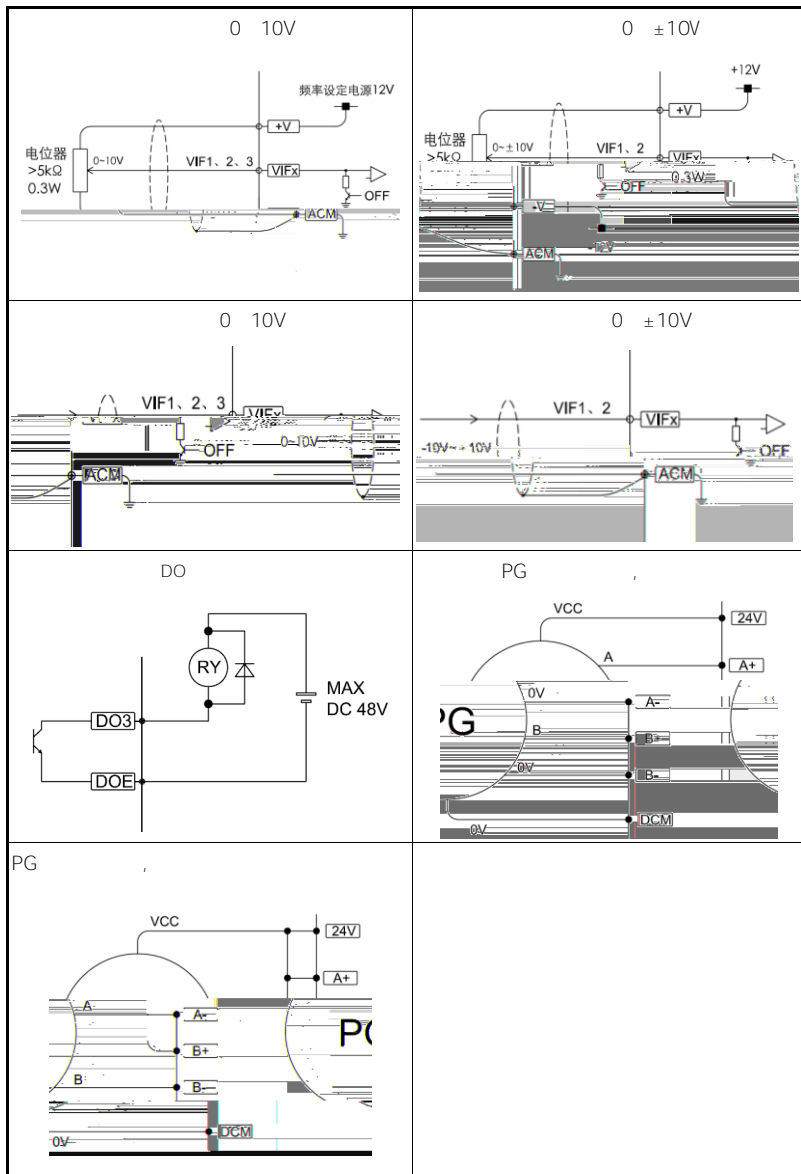

4-6

4-6-1

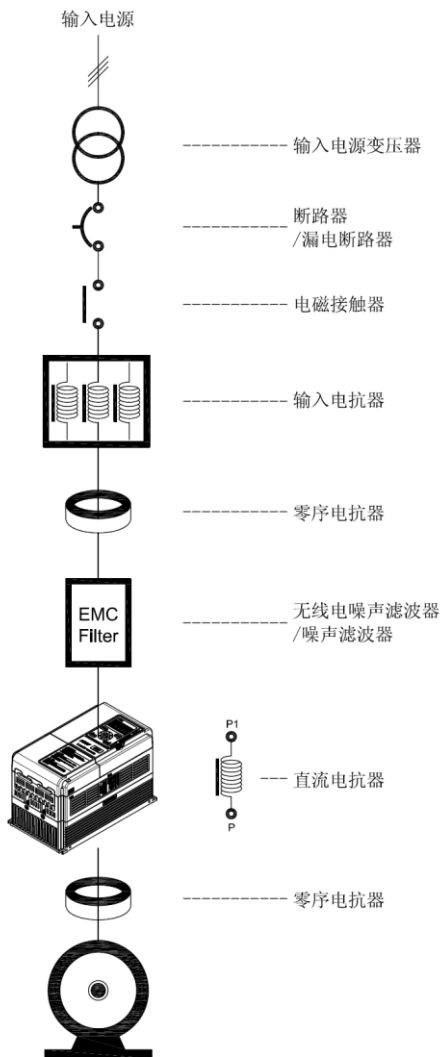







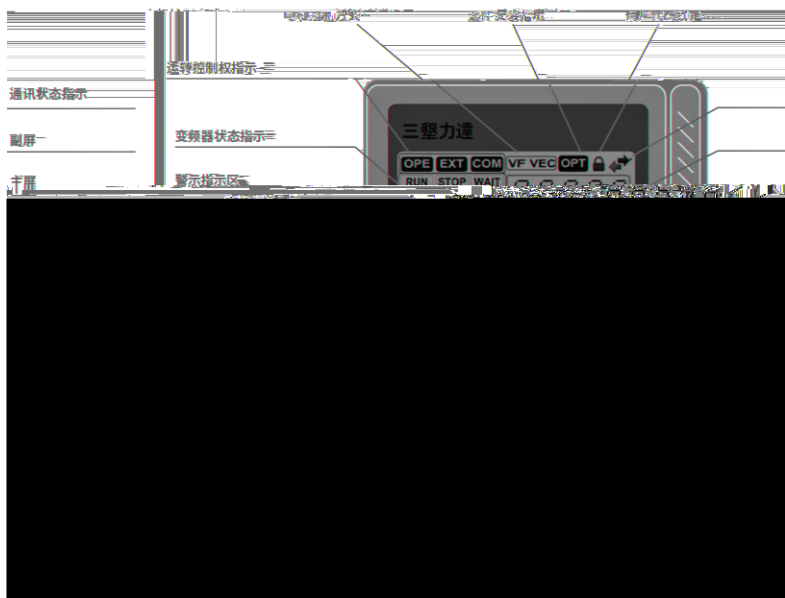

| | ■ |
|--|---|

5.

5-1

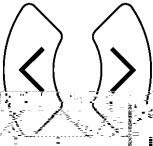

-
-
-
-
-
-
-

| | | | |
|--|--|--|--|
| |  | | |
| |  | | |
| |  | | |
| |   | | |
| |   | | |
| |  | | |
| |  | | |

5-3



| | |
|--|--|
| | |
| | |

5-3-3

5-2

| | |
|--|--|
| | |
| | |
| | |
| | |

5-3

| | | |
|--|--|--|
| | | |
| | | |
| | | |
| | | |
| | | |
| | | |
| | | |

5-4

| | | |
|--|--|--|
| | | |
|--|--|--|

5Hz 45Hz

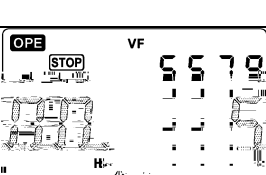
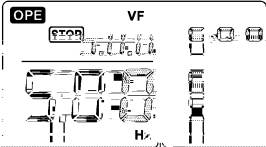
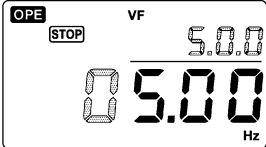
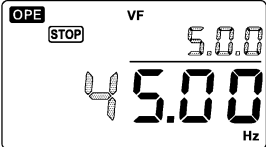
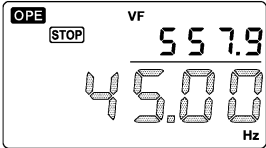
| | | |
|--|---|--|
| |  | |
| |  | |
| |  | |
| |  | |
| |  | |



5-4

5-4-1

| | | |
|--|--|--|
| | | |
| | | |

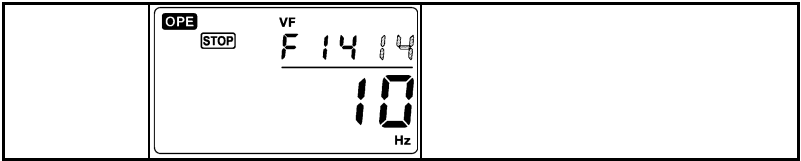

5-4-2

| | | |
|--|--|--|
| | | |
| | | |
| | | |
| | | |
| | | |
| | | |

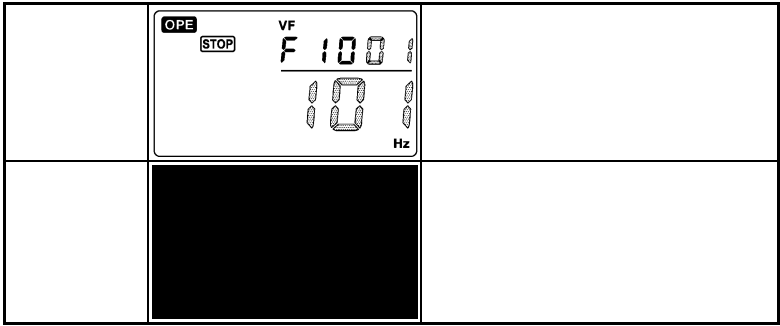

5-5

5-5-1

6.

6-1

6-1-1

6-1

| | |
|--|---------------------------------|
| | |
| | ● |
| | ● ● ● ● ● ● ● |
| | ● ● |

6-1-2

6-1-3

1

6-1-4

6-1

| | | | | |
|--|--|--|--|--|
| | | | | |
| | | | | |
| | | | | |
| | | | | |

6-2

| | | | |
|--|--|--|--|
| | | | |
| | | | |

6-1-5

6-5 2

| | | | | |
|--|--|--|--|--|
| | | | | |
| | | | | |
| | | | | |

| | | |
|--|--|--|
| | | |
| | | |
| | | |
| | | |
| | | |

| | | |
|--|--|--|
| | | |
| | | |
| | | |
| | | |
| | | |

6-1-6

2

6-7

| | | |
|--|--|--|
| | | |
| | | |
| | | |
| | | |

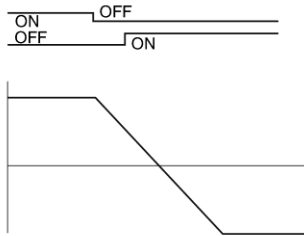
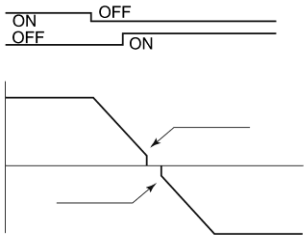

6-2

6-2

6-2-1 JOG

o

6-2-3

MBS

6-2-4

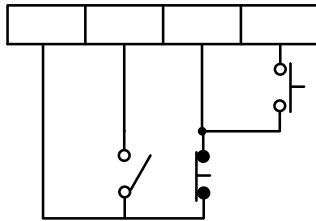

6-5

6-3

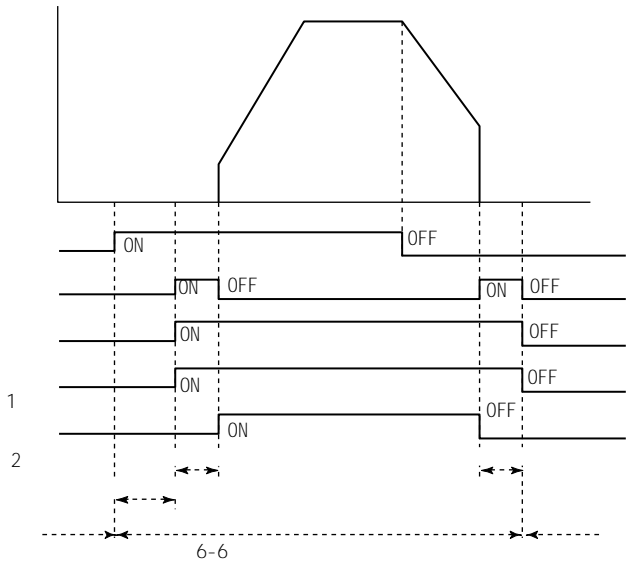

6-8

| | |
|--|--|
| | |
| | |
| | |

7-2

7-2-1

F10XX F13XX

| | | | | |
|--|--|--|--|--|
| | | | | |
| | | | | |
| | | | | |
| | | | | |
| | | | | |
| | | | | |
| | | | | |
| | | | | |
| | | | | |
| | | | | |
| | | | | |
| | | | | |
| | | | | |
| | | | | |
| | | | | |

| | | | | |
|--|--|--|--|--|
| | | | | |
| | | | | |
| | | | | |
| | | | | |
| | | | | |
| | | | | |
| | | | | |
| | | | | |
| | | | | |

7-2-2

F14XX F16XX

| F14XX F16XX | | | | |
|-------------|--|--|--|--|
| | | | | |
| | | | | |
| | | | | |
| | | | | |
| | | | | |
| | | | | |
| | | | | |
| | | | | |
| | | | | |
| | | | | |
| | | | | |
| | | | | |
| | | | | |

| | | | | | |
|--|--|--|--|--|--|
| | | | | | |
|--|--|--|--|--|--|

| | | | | |
|--|--|--|--|--|
| | | | | |
|--|--|--|--|--|

| | | | | |
|--|--|--|--|--|
| | | | | |
|--|--|--|--|--|

| | | | | |
|--|--|--|--|--|
| | | | | |
| | | | | |
| | | | | |
| | | | | |
| | | | | |

| | | | | | |
|--|--|--|--|--|--|
| | | | | | |
| | | | | | |
| | | | | | |

7-2-3

F16XX F18XX

| F16XX F18XX | | | | | |
|-------------|--|--|--|--|--|
| | | | | | |
| | | | | | |
| | | | | | |
| | | | | | |
| | | | | | |
| | | | | | |
| | | | | | |
| | | | | | |
| | | | | | |

7-2-4

F19XX F20XX

F19XX F20XX





| | | | | |
|--|--|--|--|--|
| | | | | |
| | | | | |
| | | | | |
| | | | | |
| | | | | |
| | | | | |
| | | | | |
| | | | | |
| | | | | |
| | | | | |
| | | | | |
| | | | | |
| | | | | |
| | | | | |
| | | | | |
| | | | | |
| | | | | |
| | | | | |
| | | | | |
| | | | | |
| | | | | |
| | | | | |
| | | | | |
| | | | | |

7-2-6 F23XX

| | | | | |
|-------|--|--|--|--|
| F23xx | | | | |
| | | | | |
| | | | | |
| | | | | |
| | | | | |

7-2-7 PID F30XX F33XX

| | | | | |
|-----------------|--|--|--|--|
| PID F30XX F33XX | | | | |
| | | | | |
| | | | | |
| | | | | |
| | | | | |

| | | | | |
|--|--|--|--|--|
| | | | | |
| | | | | |
| | | | | |
| | | | | |
| | | | | |
| | | | | |
| | | | | |
| | | | | |
| | | | | |
| | | | | |
| | | | | |
| | | | | |
| | | | | |
| | | | | |
| | | | | |
| | | | | |
| | | | | |
| | | | | |
| | | | | |
| | | | | |
| | | | | |
| | | | | |
| | | | | |
| | | | | |
| | | | | |
| | | | | |
| | | | | |
| | | | | |
| | | | | |
| | | | | |
| | | | | |
| | | | | |

| | | | | |
|--|--|--|--|--|
| | | | | |
| | | | | |
| | | | | |
| | | | | |
| | | | | |
| | | | | |
| | | | | |
| | | | | |
| | | | | |
| | | | | |
| | | | | |
| | | | | |
| | | | | |
| | | | | |
| | | | | |
| | | | | |
| | | | | |
| | | | | |
| | | | | |
| | | | | |
| | | | | |
| | | | | |
| | | | | |
| | | | | |
| | | | | |
| | | | | |
| | | | | |
| | | | | |
| | | | | |
| | | | | |
| | | | | |
| | | | | |
| | | | | |
| | | | | |
| | | | | |

| | | | | |
|--|--|--|--|--|
| | | | | |
| | | | | |
| | | | | |
| | | | | |
| | | | | |
| | | | | |
| | | | | |
| | | | | |
| | | | | |
| | | | | |
| | | | | |

7-2-8 F40XX F41XX

| F40XX F41XX | | | | |
|-------------|--|--|--|--|
| | | | | |
| | | | | |
| | | | | |
| | | | | |
| | | | | |
| | | | | |
| | | | | |
| | | | | |
| | | | | |
| | | | | |
| | | | | |
| | | | | |
| | | | | |
| | | | | |
| | | | | |
| | | | | |
| | | | | |
| | | | | |

7-2-9 F5XXX

| F5XXX | | | | |
|-------|--|--|--|--|
| | | | | |
| | | | | |
| | | | | |
| | | | | |
| | | | | |
| | | | | |

| | | | | |
|--|--|--|--|--|
| | | | | |
| | | | | |
| | | | | |
| | | | | |
| | | | | |
| | | | | |
| | | | | |
| | | | | |
| | | | | |
| | | | | |
| | | | | |
| | | | | |
| | | | | |
| | | | | |
| | | | | |
| | | | | |
| | | | | |
| | | | | |
| | | | | |
| | | | | |
| | | | | |

| | | |
|--|--|--|
| | | |
| | | |
| | | |
| | | |

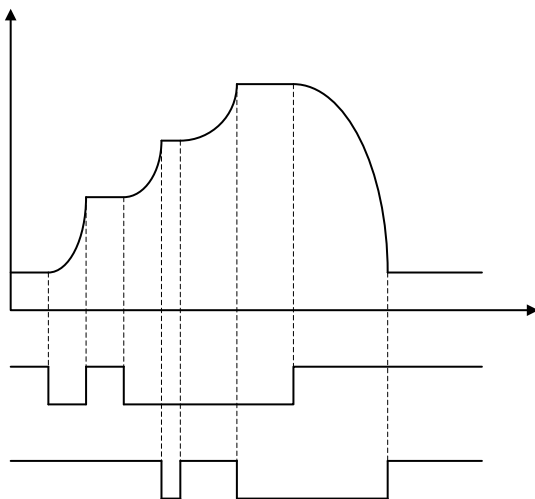

•

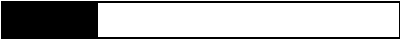

•



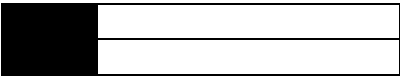
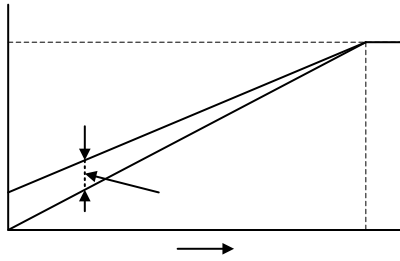

| | |
|------------|--|
| [Redacted] | |
| | |
| | |
| | |
| | |
| | |
| | |
| | |
| | |
| | |

| | | | | |
|--|--|--|--|--|
| | | | | |
| | | | | |

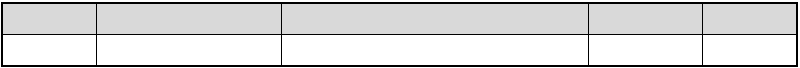
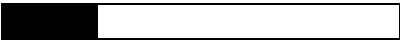
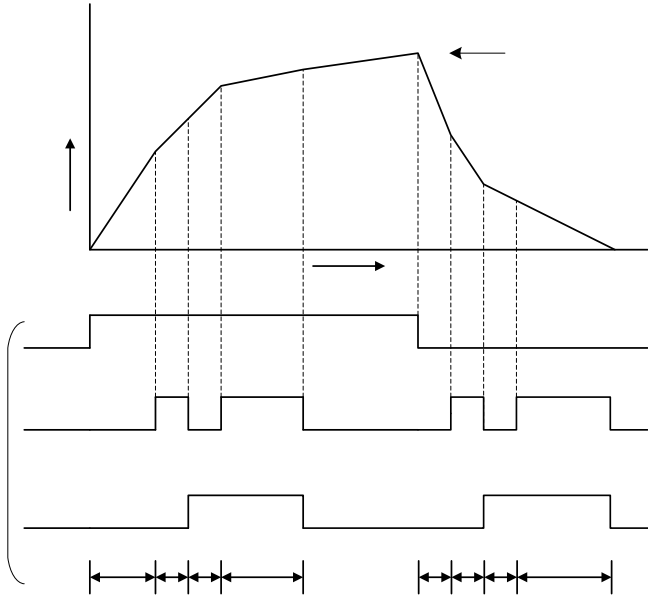



| | |
|--|--|
| | |
| | |
| | |

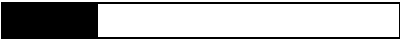
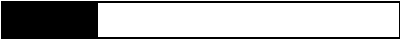

•

•

| | | |
|--|--|--|
| | | |
| | | |
| | | |
| | | |
| | | |

•

•

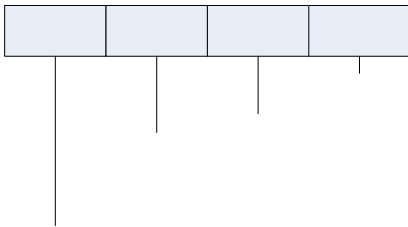

| | | | |
|--|--|--|--|
| | | | |
|--|--|--|--|

-

-

-

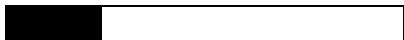
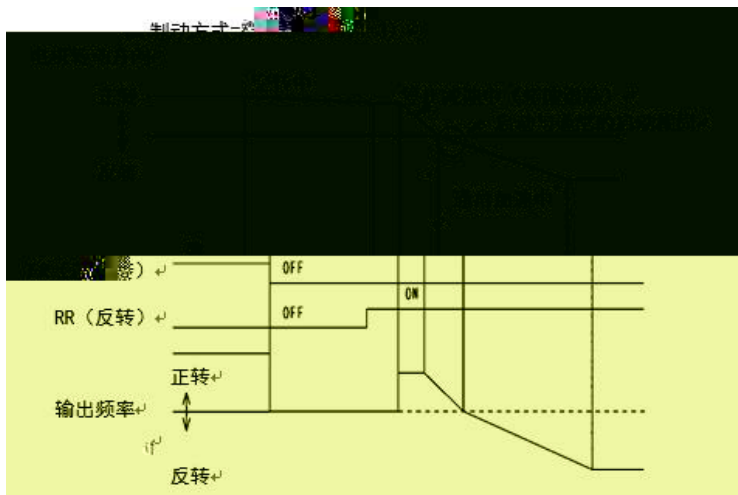

| | | | | |
|--|--|--|--|--|
| | | | | |
| | | | | |

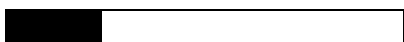

| | | | | |
|--|--|--|--|--|
| | | | | |
| | | | | |

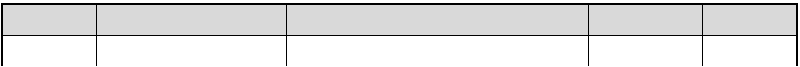
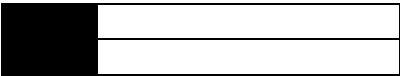
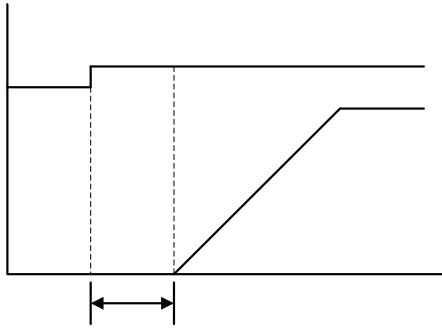
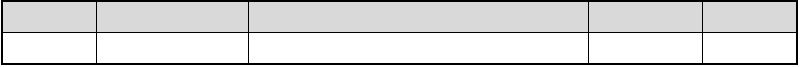
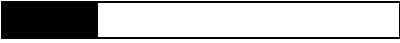

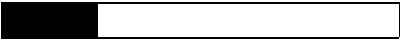
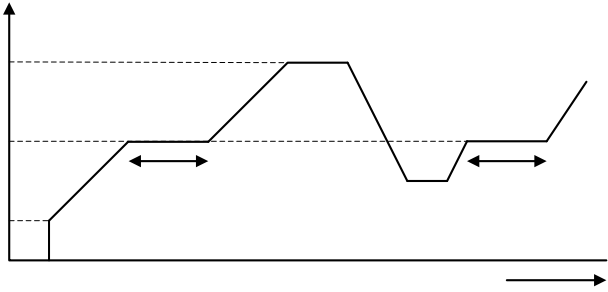

██████████

-
-

██████████

██████████

-
-
-

•

| | |
|------------|--|
| [Redacted] | |
| | |
| | |



| | |
|--|--|
| | |
| | |
| | |
| | |
| | |

| | | | | |
|--|--|--|--|--|
| | | | | |
| | | | | |
| | | | | |

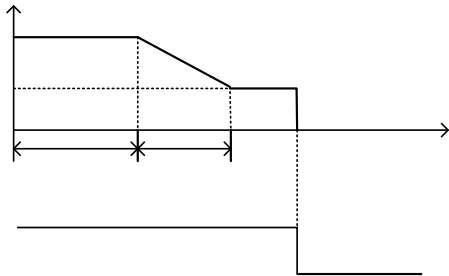

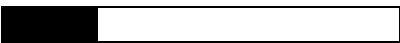
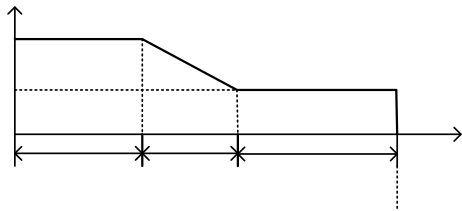
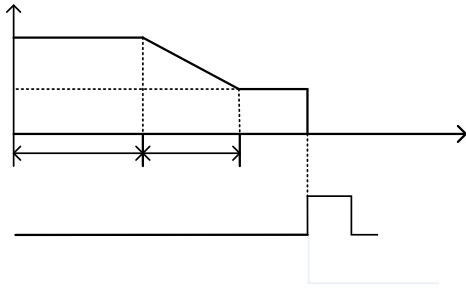

| | | | | |
|--|--|--|--|--|
| | | | | |
| | | | | |



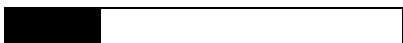
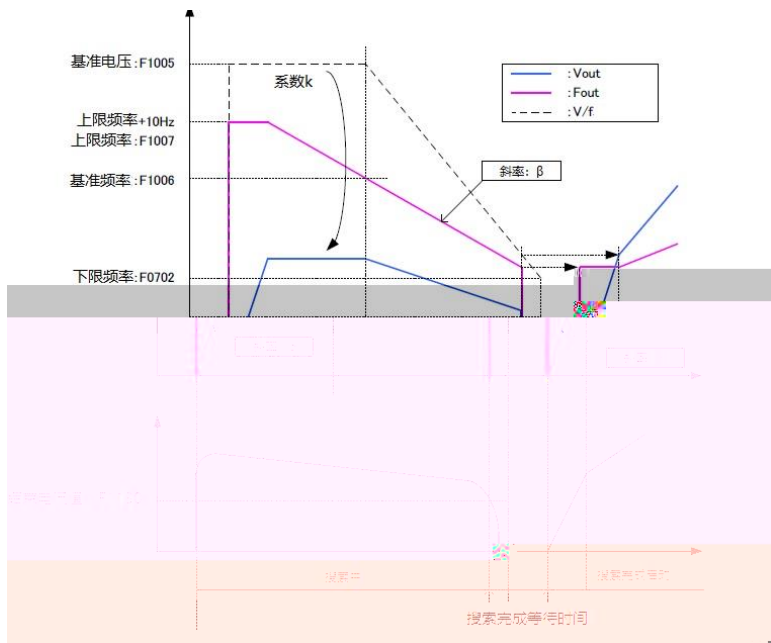

-
-

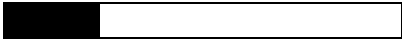



F1001=2 3 4 5 6

F1001=6





| | |
|------------|------------|
| [Redacted] | [Redacted] |
| | [Redacted] |
| | [Redacted] |



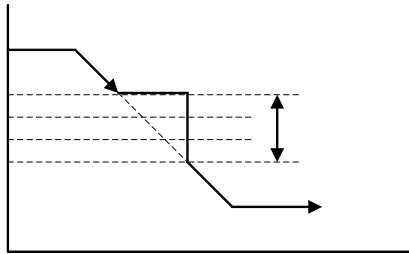

| | | | | |
|--|--|--|--|--|
| | | | | |
| | | | | |

| | | | |
|--|--|--|--|
| | | | |
| | | | |
| | | | |
| | | | |



| | | | | |
|--|--|--|--|--|
| | | | | |
| | | | | |



| | | | | |
|--|--|--|--|--|
| | | | | |
| | | | | |

•

•



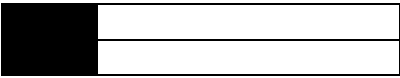
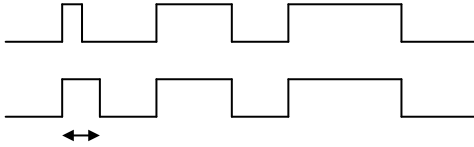

| | | | | |
|--|--|--|--|--|
| | | | | |
| | | | | |
| | | | | |



| | |
|--|--|
| | |
|--|--|

| | |
|--|--|
| | |
| | |
| | |
| | |
| | |
| | |

| | |
|--|--|
| | |
|--|--|

| | |
|--|--|
| | |
|--|--|



| | |
|--|--|
|  | |
| | |
| | |
| | |
| | |
| | |

| | |
|--|--|
| | |
| | |
| | |

| | | | | |
|--|--|--|--|--|
| | | | | |
| | | | | |

| | |
|--|--|
| | |
|--|--|

| | | | | |
|--|--|--|--|--|
| | | | | |
| | | | | |

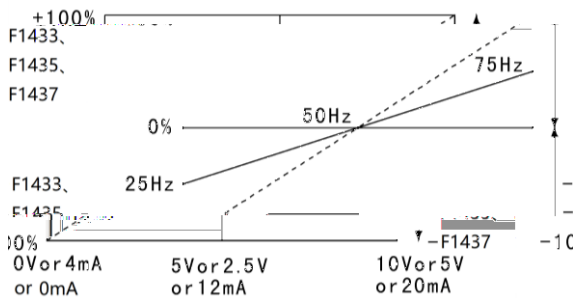

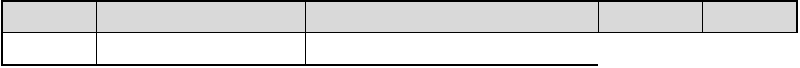
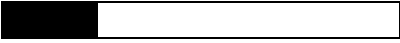

7-1

| | | | |
|--|--|--|--|
| | | | |
| | | | |
| | | | |
| | | | |
| | | | |
| | | | |
| | | | |
| | | | |
| | | | |
| | | | |

7-2

| | | |
|--|--|--|
| | | |
|--|--|--|

| | | |
|--|--|--|
| | | |
| | | |
| | | |
| | | |
| | | |



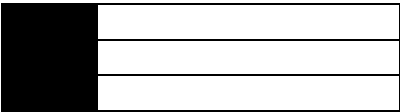

| | |
|------------|--|
| [Redacted] | |
| | |
| | |



$$VIF1_{zw} = (VIF1_{max} - VIF1_{cen}) \times \frac{F[1429]}{100}$$

$$VIF2_{zw} = (VIF2_{max} - VIF2_{cen}) \times \frac{F[1430]}{100}$$

$$VIF3_{zw} = (VIF3_{max} - VIF3_{cen}) \times \frac{F[1431]}{100}$$

| | |
|--|--|
| | |
| | |
| | |
| | |
| | |
| | |
| | |
| | |
| | |
| | |
| | |
| | |

| | |
|--|--|
| | |
| | |
| | |
| | |
| | |
| | |
| | |
| | |
| | |

| | | | | | |
|--|--|--|--|--|--|
| | | | | | |
| | | | | | |
| | | | | | |
| | | | | | |

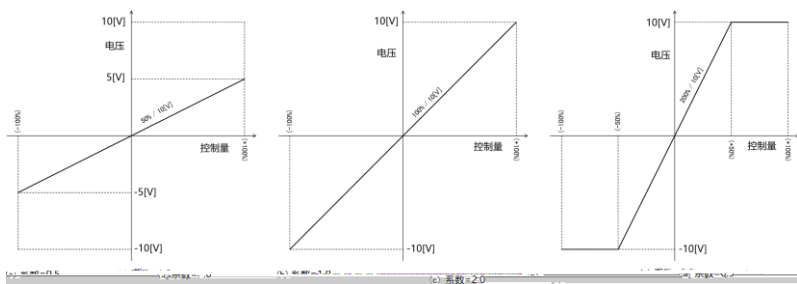

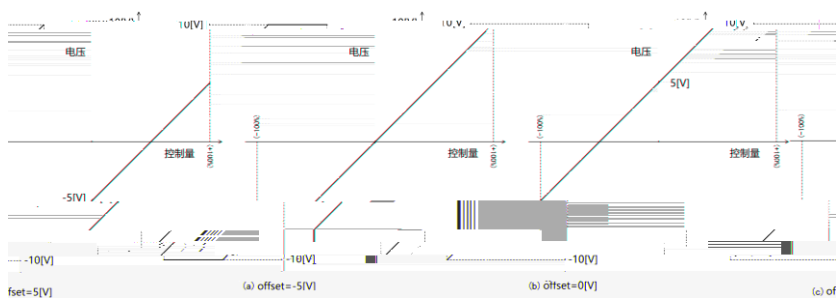
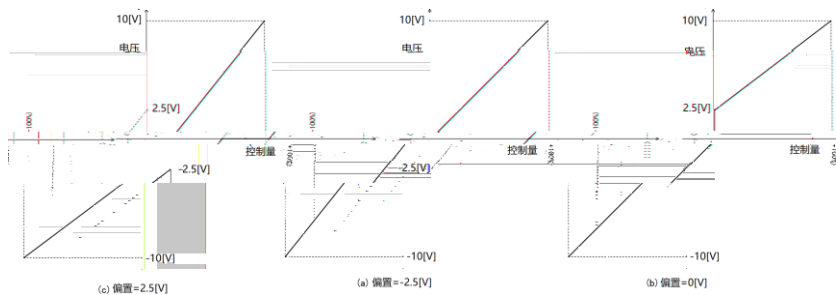

| | | |
|--|--|--|
| | | |
| | | |
| | | |

7-4 / (,400V)

| | |
|--|--|
| | |
| | |
| | |
| | |
| | |
| | |

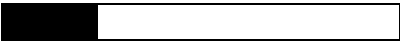

| | | | | |
|--|--|--|--|--|
| | | | | |
| | | | | |

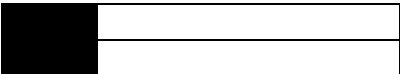

| | | |
|--|--|--|
| | | |
|--|--|--|

| | | | | |
|--|--|--|--|--|
| | | | | |
| | | | | |

| | |
|--|--|
| | |
| | |
| | |

| | | | | |
|--|--|--|--|--|
| | | | | |
|--|--|--|--|--|

| | | | | | |
|--|--|--|--|--|--|
| | | | | | |
|--|--|--|--|--|--|

| | |
|--|--|
| | |
| | |

| | | | | |
|--|--|--|--|--|
| | | | | |
| | | | | |
| | | | | |

| | |
|--|--|
| | |
| | |

| | | | | |
|--|--|--|--|--|
| | | | | |
| | | | | |

| | | | | |
|--|--|--|--|--|
| | | | | |
| | | | | |

[Redacted]

7-3-3

[Redacted]

[Redacted]



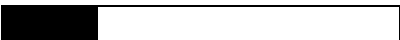

| | | | | |
|--|--|--|--|--|
| | | | | |
|--|--|--|--|--|

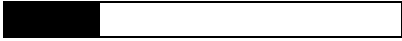



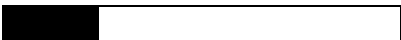

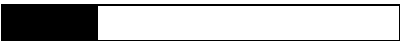
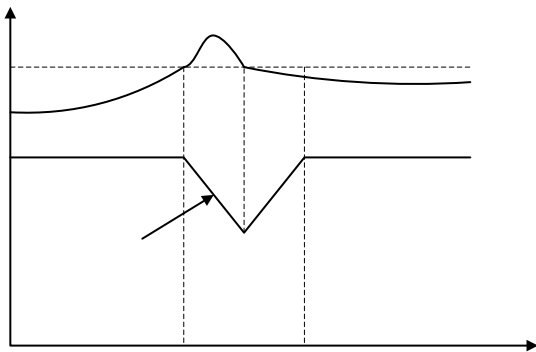

| | | | | |
|--|--|--|--|--|
| | | | | |
| | | | | |

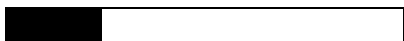

| | | | | |
|--|--|--|--|--|
| | | | | |
| | | | | |

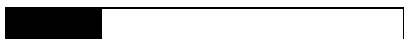

| | | | | |
|--|--|--|--|--|
| | | | | |
| | | | | |

ou Lu

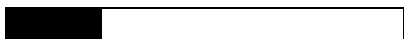

| | | | | |
|--|--|--|--|--|
| | | | | |
| | | | | |

oPn i
oPn o

██████████

-
-

██████████

-
-
-

██████████

-
-
-



| | | | | |
|--|--|--|--|--|
| | | | | |
| | | | | |

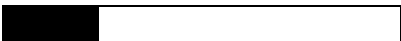

| | | | | |
|--|--|--|--|--|
| | | | | |
| | | | | |



| | | | | |
|--|--|--|--|--|
| | | | | |
| | | | | |

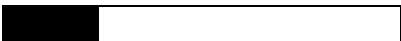

| | | | | |
|--|--|--|--|--|
| | | | | |
| | | | | |

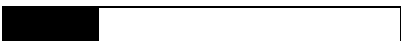

-
-

| | |
|--|--|
| | |
| | |
| | |
| | |
| | |

| | |
|--|--|
| | |
|--|--|



| | |
|--|--|
|  | |
| | |
| | |

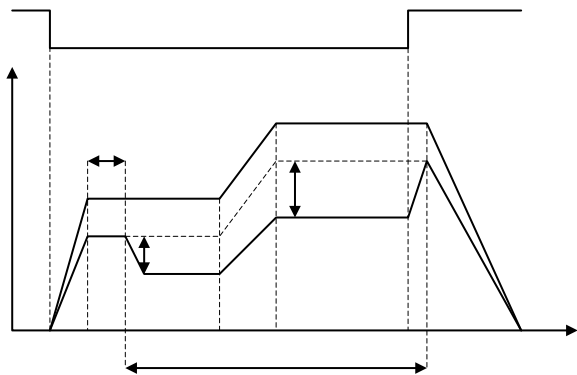

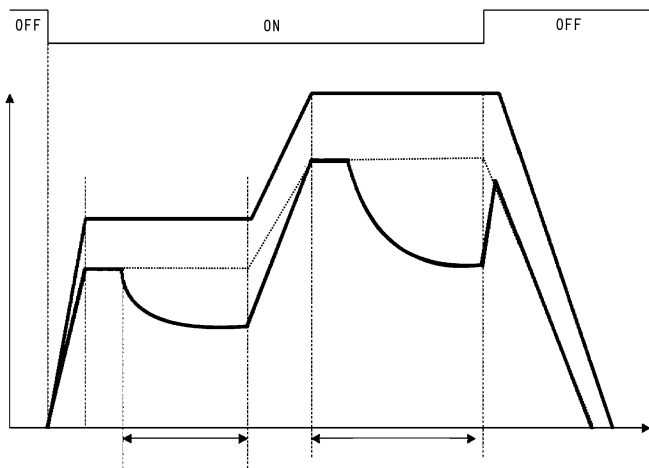

V.f

| | |
|------------|--|
| [Redacted] | |
| | |
| | |
| | |

| | . | | | |
|--|---|--|--|--|
| | . | | | |

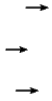

V/f

| | |
|--|--|
| | |
| | |
| | |
| | |

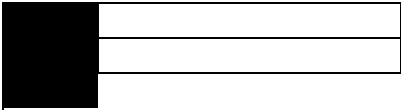
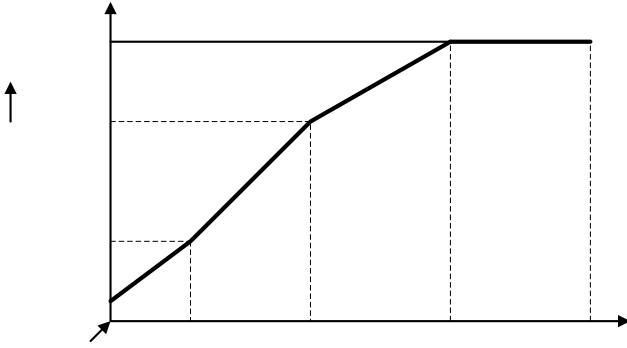

| | | | | |
|--|--|--|--|--|
| | | | | |
| | | | | |

7-3-5



| | |
|--|--|
| | |
| | |
| | |
| | |

| | |
|------------|--|
| [REDACTED] | |
| | |
| | |
| | |
| | |
| | |
| | |
| | |
| | |
| | |
| | |
| | |
| | |

| | | | |
|--|--|--|--|
| | | | |
| | | | |
| | | | |
| | | | |

| | |
|---|--|
|  | |
| | |
| | |
| | |
| | |
| | |
| | |
| | |
| | |
| | |
| | |
| | |
| | |
| | |
| | |

| | | | | |
|--|--|--|--|--|
| | | | | |
|--|--|--|--|--|

| | |
|------------|--|
| [Redacted] | |
| | |
| | |
| | |
| | |
| | |
| | |
| | |
| | |
| | |
| | |
| | |
| | |
| | |
| | |

| | |
|------------|--|
| [Redacted] | |
|------------|--|

| | | | | |
|--|--|--|--|--|
| | | | | |
| | | | | |

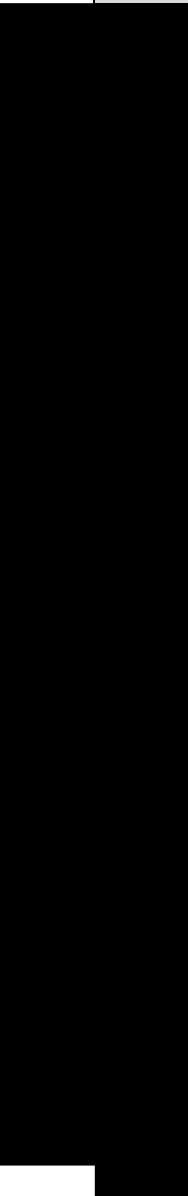

| | |
|--|---|
| | → |
| | |

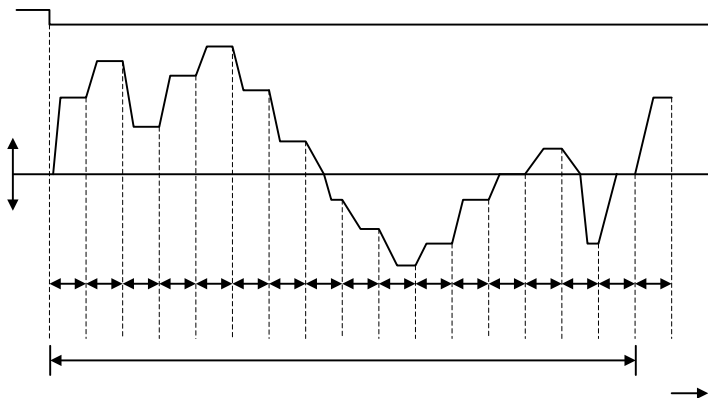

| | |
|--|--|
| | |
| | |

| | | | | |
|--|--|--|--|--|
| | | | | |
| | | | | |

| | | | | |
|--|--|--|--|--|
| | | | | |
| | | | | |

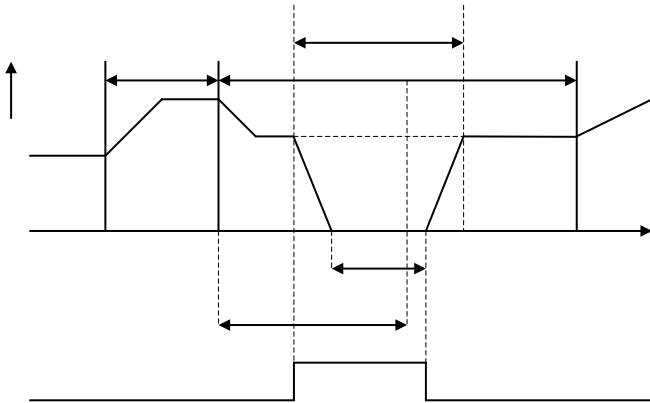

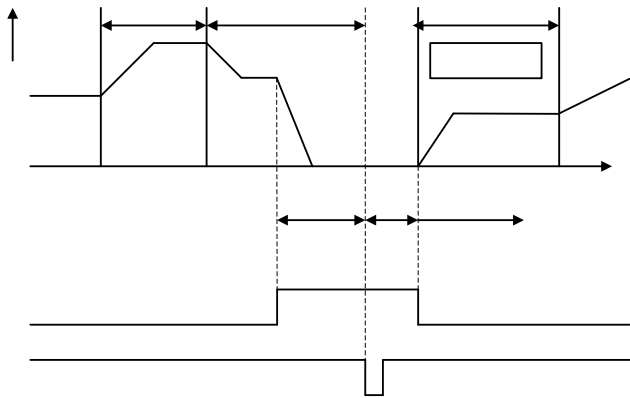

1





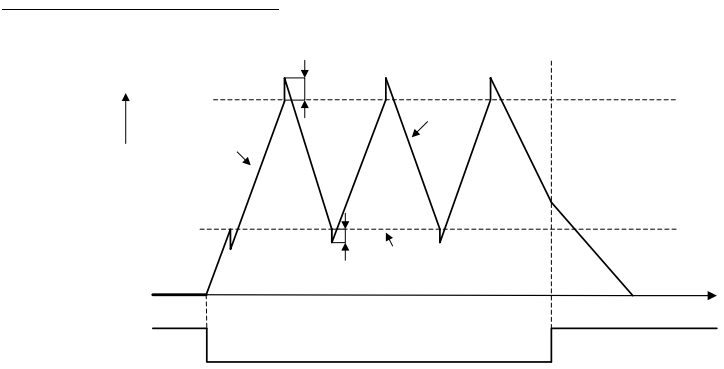
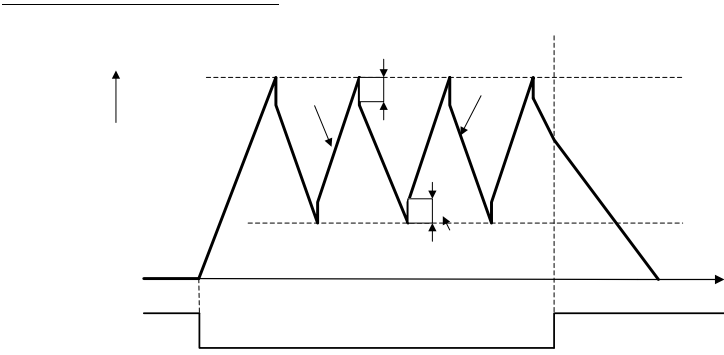

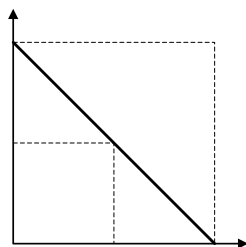
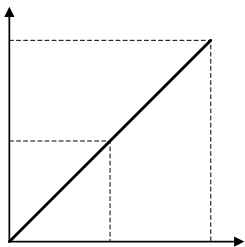

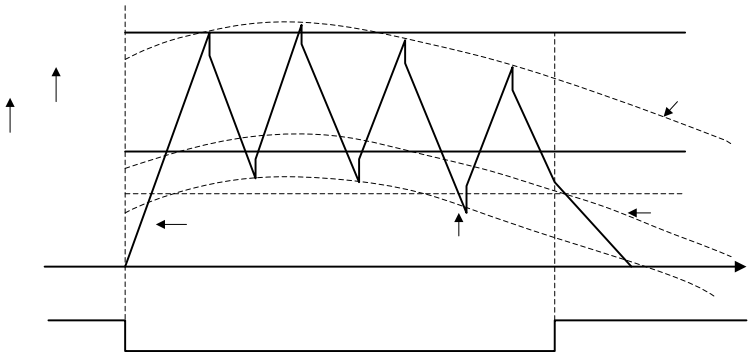
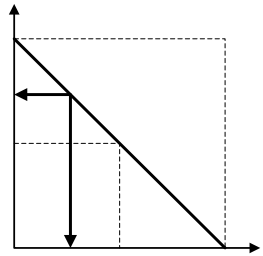
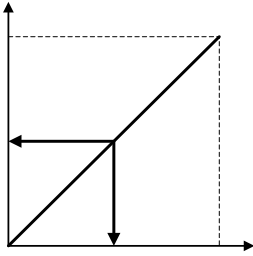

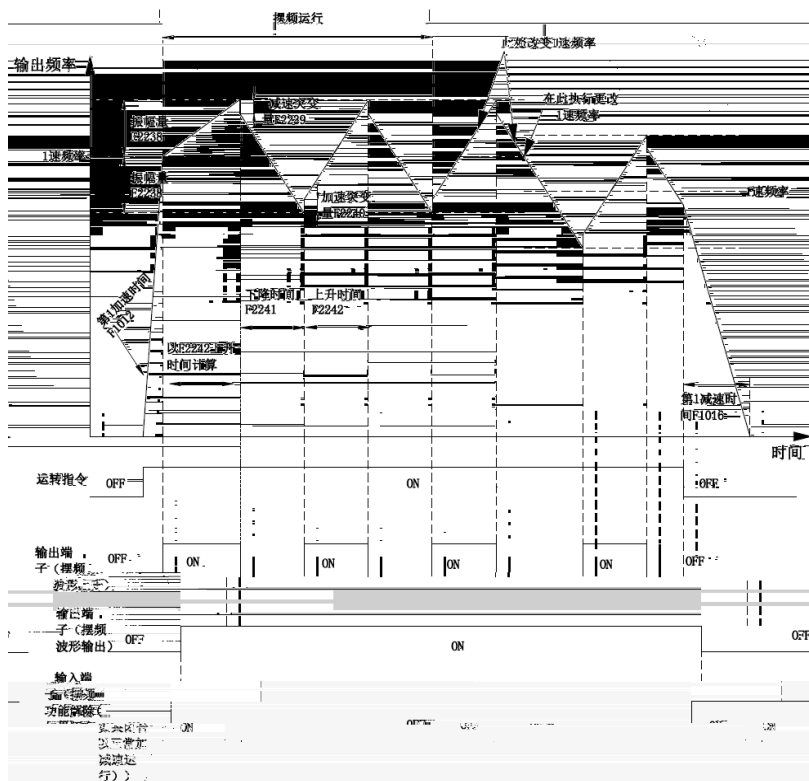

PID

| | | | | |
|--|--|--|--|--|
| | | | | |
| | | | | |
| | | | | |
| | | | | |
| | | | | |
| | | | | |



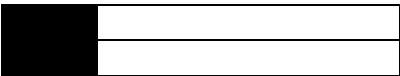

| | |
|--|--|
| | |
| | |
| | |
| | |
| | |
| | |

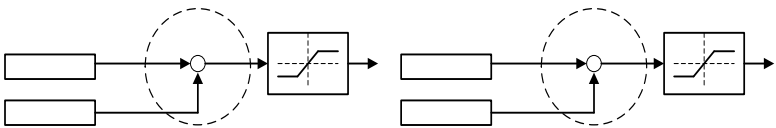
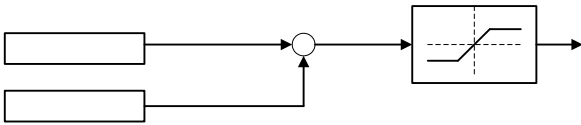
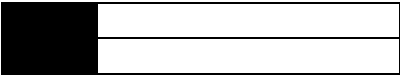

| | |
|------------|--|
| [Redacted] | |
| | |
| | |
| | |
| | |
| | |

| | |
|------------|--|
| [Redacted] | |
| | |

| | |
|------------|--|
| [Redacted] | |
| | |

PID

| | |
|--|--|
| | |
| | |

| | |
|--|--|
| | |
| | |
| | |

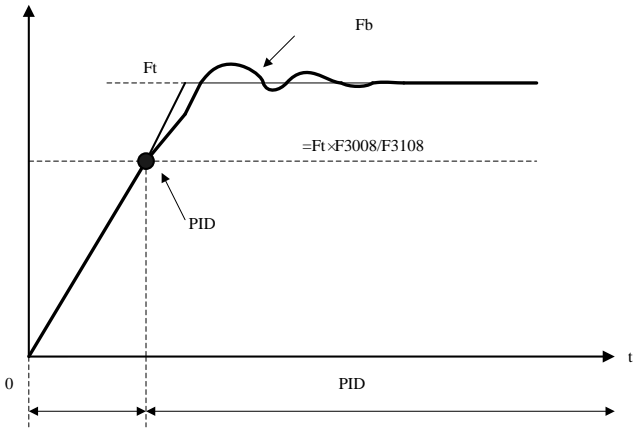

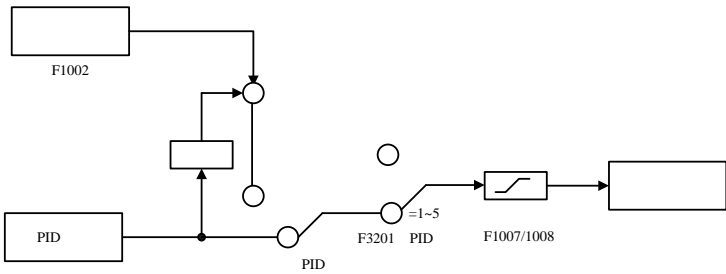
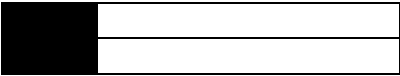

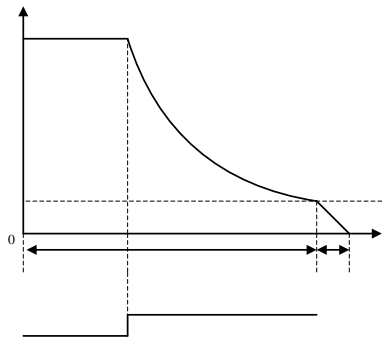
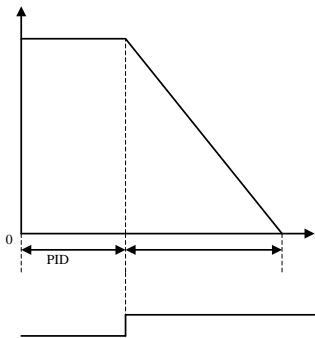
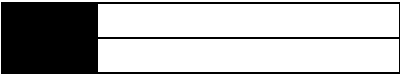

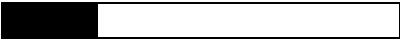

FbEr

GAL 1

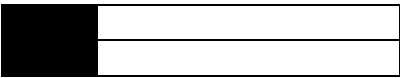

| | | | | |
|--|--|--|--|--|
| | | | | |
| | | | | |
| | | | | |

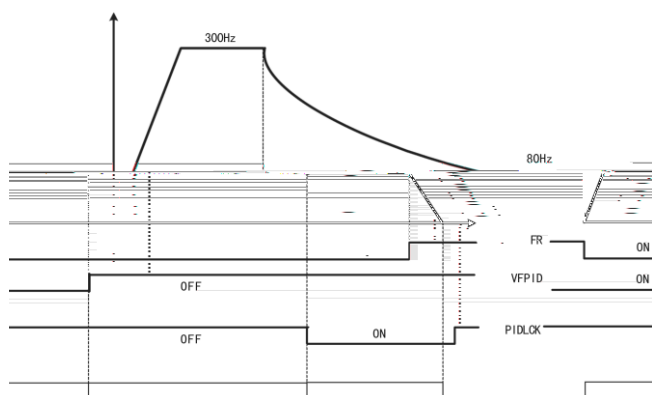

PID

PID

| | | |
|--|--|--|
| | | |
| | | |
| | | |
| | | |
| | | |
| | | |
| | | |

PID

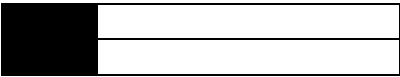
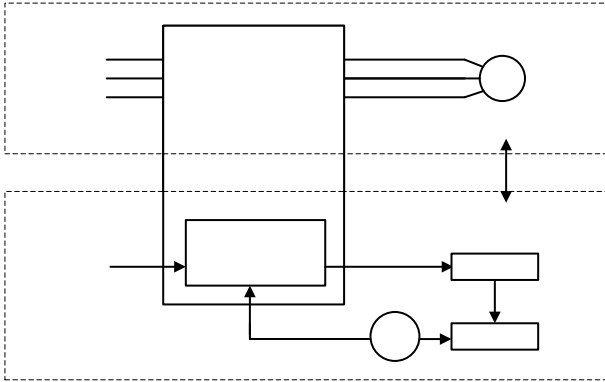

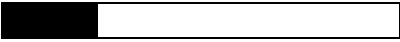

| | | | | |
|--|--|--|--|--|
| | | | | |
| | | | | |



| | | | | |
|--|--|--|--|--|
| | | | | |
| | | | | |



| | | | | |
|--|--|--|--|--|
| | | | | |
| | | | | |

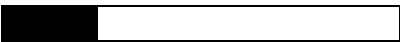

| | | | | |
|--|--|--|--|--|
| | | | | |
| | | | | |



| | | | | |
|--|--|--|--|--|
| | | | | |
| | | | | |

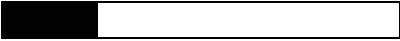

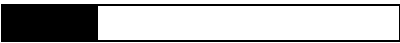









| | | | | |
|--|--|--|--|--|
| | | | | |
|--|--|--|--|--|

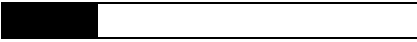

| | | | | |
|--|--|--|--|--|
| | | | | |
| | | | | |



| | | | | |
|--|--|--|--|--|
| | | | | |
| | | | | |

| | |
|--|--|
| | |
| | |

| | | | | |
|--|--|--|--|--|
| | | | | |
|--|--|--|--|--|

E_{xxxx} Er C

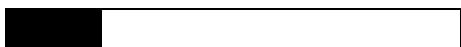

| | | | | |
|--|--|--|--|--|
| | | | | |
| | | | | |

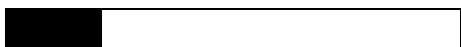

| | | | | |
|--|--|--|--|--|
| | | | | |
| | | | | |

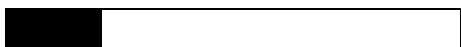

| | | | | |
|--|--|--|--|--|
| | | | | |
| | | | | |

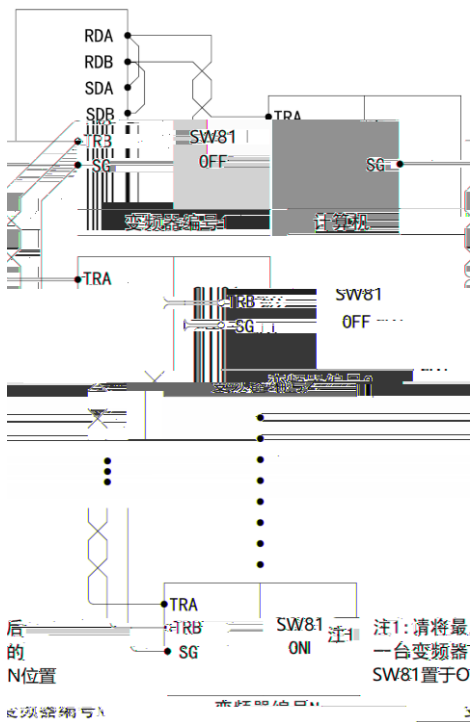

| | | | | | | |
|--|--|--|--|--|--|--|
| | | | | | | |
| | | | | | | |
| | | | | | | |
| | | | | | | |
| | | | | | | |

| | | |
|--|--|--|
| | | |
| | | |
| | | |
| | | |
| | | |
| | | |
| | | |
| | | |

7-4-5

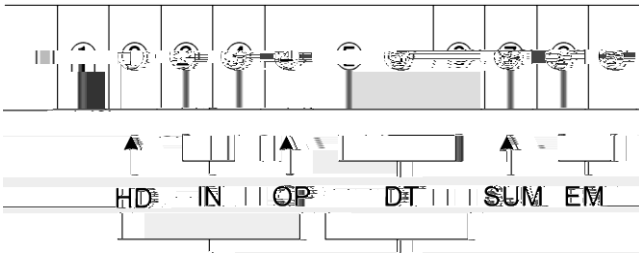

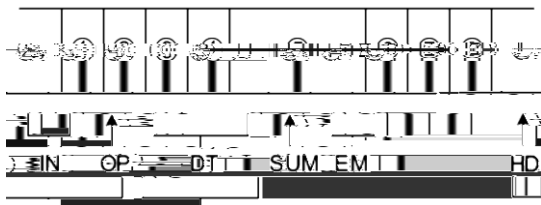

| | | | |
|--|--|--|--|
| | | | |
| | | | |

| | | | | | | | | | | |
|--|--|--|--|--|--|--|--|--|--|--|
| | | | | | | | | | | |
| | | | | | | | | | | |

| | | | | | |
|--|--|--|--|--|--|
| | | | | | |
| | | | | | |

| | | | | | | | | | | |
|--|--|--|--|--|--|--|--|--|--|--|
| | | | | | | | | | | |
|--|--|--|--|--|--|--|--|--|--|--|

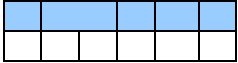
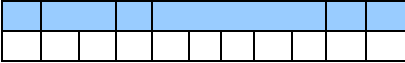
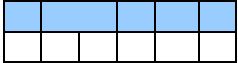
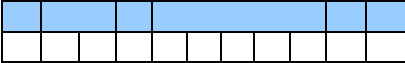
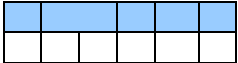
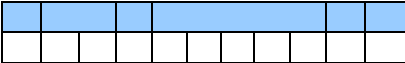
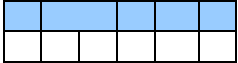
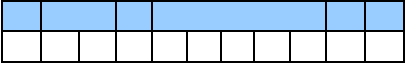
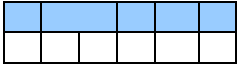
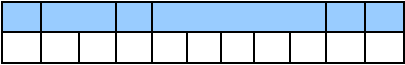
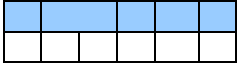
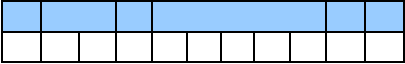
| | | |
|--|---|---|
| |  |  |
| |  |  |
| |  |  |
| |  |  |
| |  |  |
| |  |  |

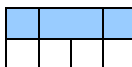

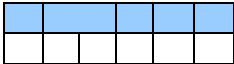
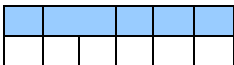
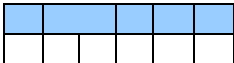
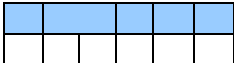
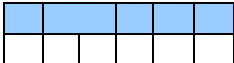
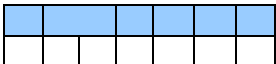

| | | |
|--|---|---|
| |  | |
| |  | |
| |  | |
| |  | |
| |  | |
| | |  |

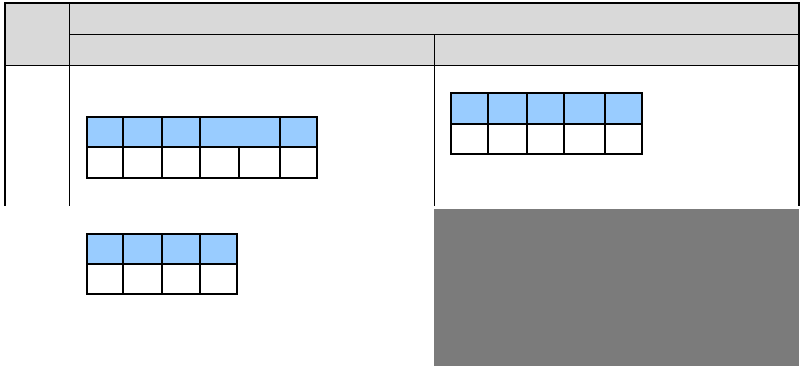

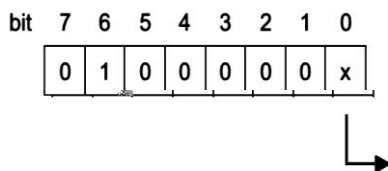
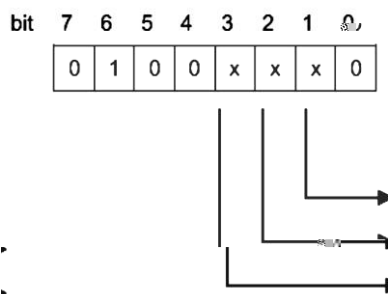
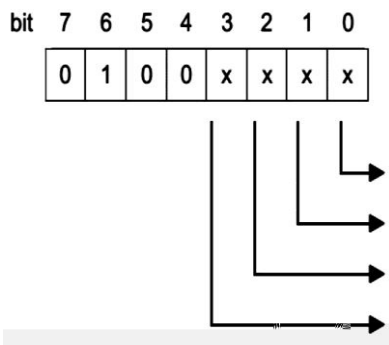

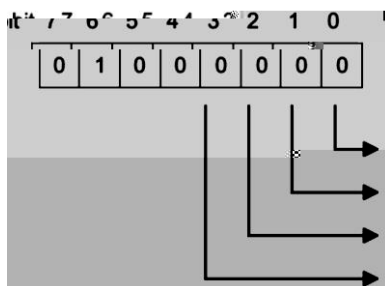
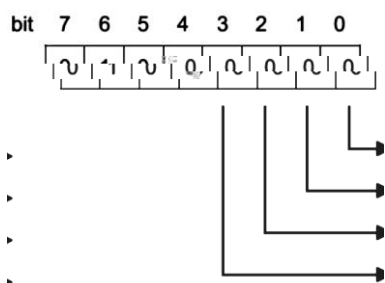
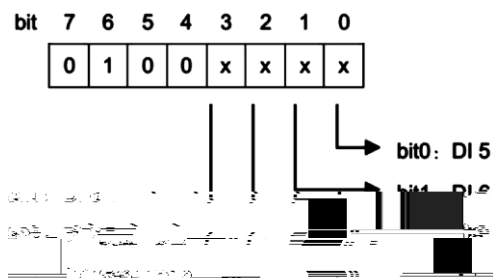
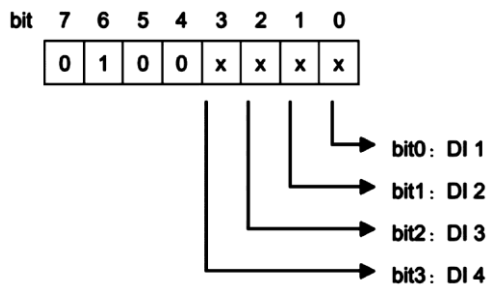

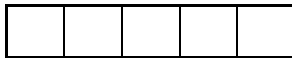

| | 0 | 1 | 2 | 3 | 4 | 5 | 6 | 7 | 8 | 9 | A | B | C | D | E | F | |
|---|---|---|---|---|---|---|---|---|---|---|---|---|---|---|---|---|---|
| 0 | | D | E | | 0 | @ | P | ' | p | | | | - | タ | ミ | | ⊗ |

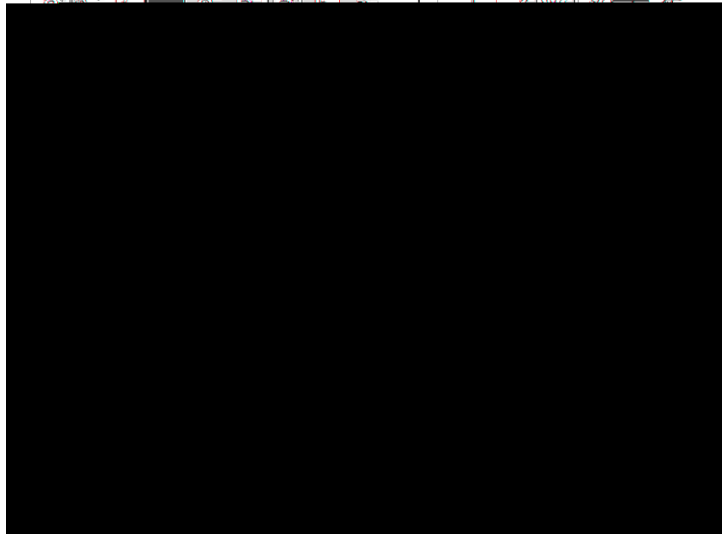

7-4-6 ModBus-RTU



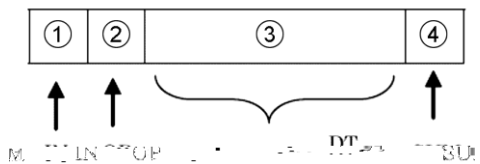

| | |
|--|--|
| | |
| | |
| | |
| | |
| | |
| | |
| | |
| | |
| | |
| | |

| | | | | | | | | | | | | | | | | | | |
|--|--|--|--|--|--|--|--|--|--|--|--|--|--|--|--|--|--|--|
| | | | | | | | | | | | | | | | | | | |
| | | | | | | | | | | | | | | | | | | |
| | | | | | | | | | | | | | | | | | | |
| | | | <div style="text-align: center; margin-bottom: 20px;"> <table border="1" style="display: inline-table; border-collapse: collapse;"> <tr> <td style="width: 20px; height: 15px;"></td> <td style="width: 20px; height: 15px;"></td> <td style="width: 20px; height: 15px;"></td> <td style="width: 20px; height: 15px;"></td> </tr> </table> </div> <div style="text-align: center; margin-bottom: 20px;"> <table border="1" style="display: inline-table; border-collapse: collapse;"> <tr> <td style="width: 20px; height: 15px;"></td> <td style="width: 20px; height: 15px;"></td> <td style="width: 20px; height: 15px;"></td> <td style="width: 20px; height: 15px;"></td> </tr> </table> </div> <div style="text-align: center;"> <table border="1" style="display: inline-table; border-collapse: collapse;"> <tr> <td style="width: 20px; height: 15px;"></td> <td style="width: 20px; height: 15px;"></td> <td style="width: 20px; height: 15px;"></td> <td style="width: 20px; height: 15px;"></td> <td style="width: 20px; height: 15px;"></td> <td style="width: 20px; height: 15px;"></td> <td style="width: 20px; height: 15px;"></td> </tr> </table> </div> | | | | | | | | | | | | | | | |
| | | | | | | | | | | | | | | | | | | |
| | | | | | | | | | | | | | | | | | | |
| | | | | | | | | | | | | | | | | | | |
| | | | | | | | | | | | | | | | | | | |

| | | | |
|--|--|--|--|
| | | | |
|--|--|--|--|

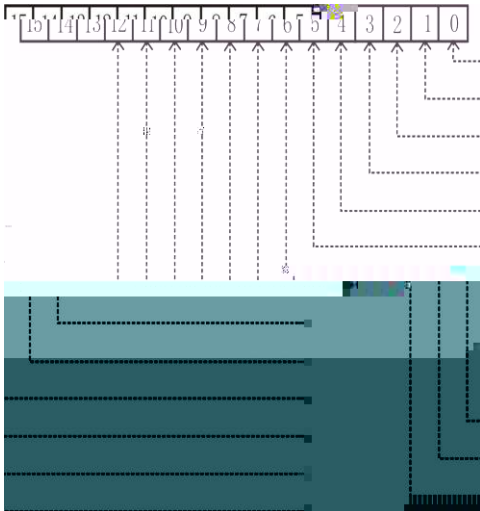

| | | | | | | |
|--|--|--|--|--|--|--|
| | | | | | | |
| | | | | | | |
| | | | | | | |
| | | | | | | |
| | | | | | | |
| | | | | | | |
| | | | | | | |

8.

8-1

8-1

| SC | | |
|-----------------|--|--|
| SC _n | | |
| S _u | | |
| oL | | |
| tH | | |
| dboH | | |
| FinE | | |
| CLER | | |
| UIER | | |

8-2

| RL | 1 | | |
|----|---|--|--|
| RL | 2 | | |
| RL | 3 | | |

RL 4

| | | | |
|-------|--|--|--|
| | | | |
| oUn | | | |
| oUd | | | |
| oUP | | | |
| GRL 1 | | | |
| GRL 2 | | | |
| GRL 3 | | | |
| PonG | | | |
| oPn o | | | |
| oPn i | | | |
| Gnd F | | | |
| FRn L | | | |
| rYoff | | | |

10.



10-1



10-2

10-3

10-1

| | | | | |
|--|--|--|--|--|
| | | | | |
| | | | | |
| | | | | |

10-5

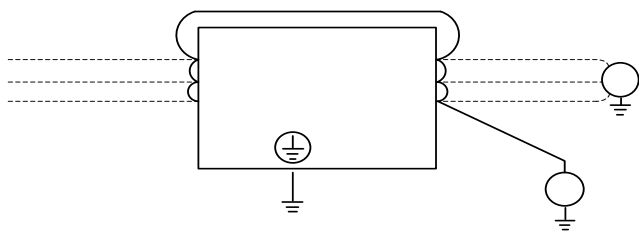

10-6

$$\frac{\text{功率[W]}}{\sqrt{3} \times \text{电压[V]} \times \text{电流[A]}} \times 100 \quad \text{功率因数}[\%] =$$

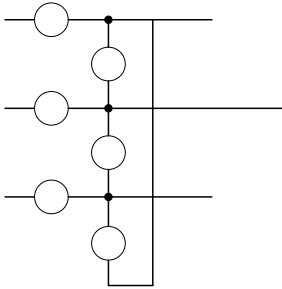

10-7

10-5

11.

11-1

| | | | | | | | | | | |
|--|--|--|--|--|--|--|--|--|--|--|
| | | | | | | | | | | |
| | | | | | | | | | | |

11-2

| | |
|--|--|
| | |
| | |
| | |

11-4

| | | |
|--|--|--|
| | | |
| | | |
| | | |
| | | |

12.

12-1

13.

2024 2

U2001

TEXC-HS701-004